

CASES and KITS

For Analog Handheld Instruments

PRICE LIST



JANUARY 1, 2011

For Model(s):
Any DS/pDS
Meter

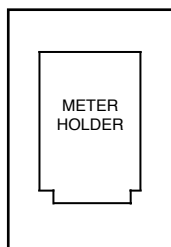

PRODUCT: Porta-Pak
MODEL #: PTP
INCLUDES: Small hard foam-lined carry case
DIMENSIONS*: 8.5 L x 5.4 W x 4.5 D in. / 216 L x 137 W x 114 D mm
PRICE: \$42.50

For Model(s):
PK3 - T2/PH
T6/PH
PK7 - EP11/PH

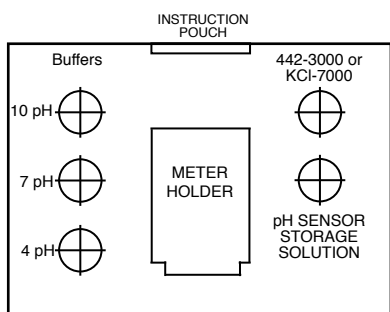

PRODUCT: Porta-Kit
MODEL #: PK3 and PK7
INCLUDES: Large hard foam-lined protective carry case, 2 oz./59 ml each of pH 4, 7, & 10 Buffers, pH Sensor Storage Solution, and either 442-3000 or KCl-7000
DIMENSIONS*: 13.6 L x 10 W x 5.4 D in. / 346 L x 254 W x 137 D mm
PRICE: \$71.00

For Model(s):
512M5

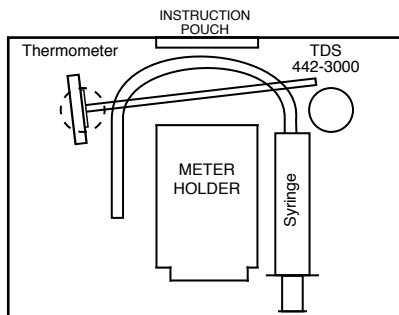

PRODUCT: Litho-Kit™
MODEL #: CLK
INCLUDES: Large hard foam-lined protective carry case, 2 oz./59 ml of 442-3000, graduated 35CC syringe and thermometer
DIMENSIONS*: 13.6 L x 10 W x 5.4 D in. / 346 L x 254 W x 137 D mm
PRICE: \$100.00

For Model(s):
M6/PH

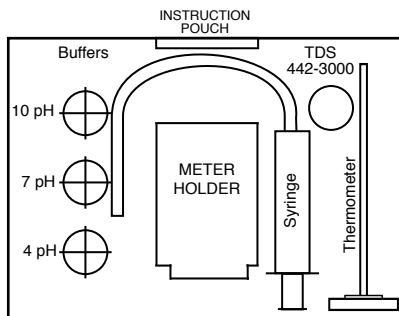

PRODUCT: Litho-Kit™
MODEL #: PLK
INCLUDES: Large hard foam-lined protective carry case, 2 oz./59 ml each of 442-3000 and pH 4, 7, & 10 Buffers, graduated 35CC syringe and thermometer
DIMENSIONS*: 13.6 L x 10 W x 5.4 D in. / 346 L x 254 W x 137 D mm
PRICE: \$112.00

Continued

For Model(s):
AG-5

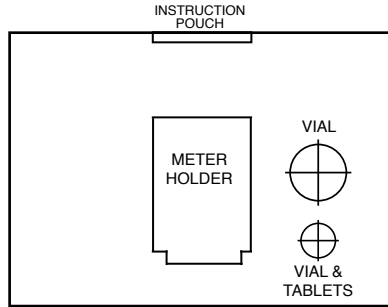

PRODUCT: Soil Test Kit
MODEL #: STK
INCLUDES: Large hard foam-lined protective carry case, soil test vials, ppm Alkalinity Test Kit
DIMENSIONS*: 13.6 L x 10 W x 5.4 D in. / 346 L x 254 W x 137 D mm
PRICE: \$57.00

For Model(s):
AG6/PH

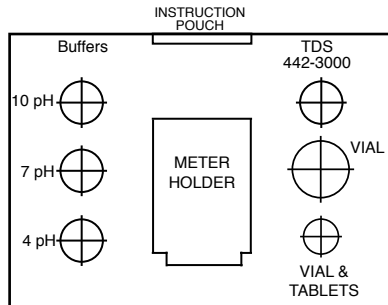

PRODUCT: Soil Test Kit
MODEL #: PSTK
INCLUDES: Large hard foam-lined protective carry case, 2 oz./ 59 ml each of pH 4, 7, & 10 Buffers and 442-3000, soil test vials, ppm Alkalinity Test Kit
DIMENSIONS*: 13.6 L x 10 W x 5.4 D in. / 346 L x 254 W x 137 D mm
PRICE: \$85.00

PRODUCT: Alkalinity Test Kit
MODEL#: ATK
INCLUDES: 1 vial and 20 tablets (no case)
DIMENSIONS*: Vial: 4 H x 1 in. Dia. / 102 H x 25 mm Dia.
PRICE: \$21.00

** Dimensions are approximate.*

TERMS AND CONDITIONS *(Additional information upon request)*

All special order items are non-returnable and non-refundable.
Minimum order \$25.00. All prices are US dollars and are F.O.B Carlsbad, CA.
Terms: 1% 10 days, net 30 days on approved credit.
Credit Cards accepted: Visa, MasterCard and American Express
Because of our policy of continuous product improvement, the Myron L Company reserves the right to make changes in design, specifications, and prices without notice.

2450 Impala Drive
Carlsbad, CA 92010-7226 USA
Tel: +1-760-438-2021
Fax: +1-800-869-7668 / +1-760-931-9189
www.myronl.com

Built On Trust. Founded in 1957, the Myron L Company is one of the world's leading manufacturers of water quality instruments. Because of our commitment to product improvement, changes in design and specifications are possible. You have our assurance any changes will be guided by our product philosophy: accuracy, reliability, and simplicity.

